

# TECHNICAL INFORMATION

## STENI wood screws

### INSTALLING STENI PANELS ONTO A WOOD BACKING

#### DIMENSIONS

4.0 x 28 mm  
4.0 x 33 mm

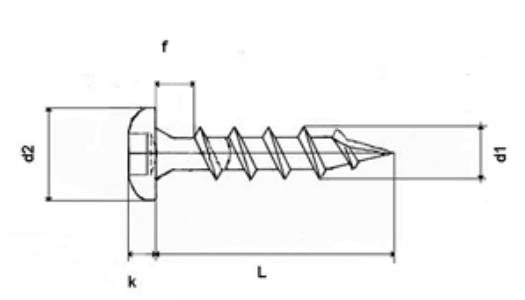

Dimensions in mm.

d1	d2	L	k	f	Screw bits
4.0	8.7	28	2.5	5.0	R1 or T-20
4.0	8.7	33	2.5	5.0	R1 or T-20

#### MATERIAL

Acid-proof steel A4 – ISO 3506.

#### CORROSION CLASS

C5.

#### SCREW HEAD

Untreated or powder-coated on Zinc primer.

#### QUANTITY

500 screws/carton.

#### CAPACITY

Wood, Fd = 341 N/ screw. NS-EN 1995-1-1:2004.  
Minimum 15 mm anchor into the wood.

Untreated wood with a minimum quality of C18 RH 20% (EN 338)  
Impregnated wood with a minimum quality of C18 RH 20% (AB ref. NTR document no.1.UC3 in accordance with EN 335 and NP5 in accordance with EN 351-1).

An on-site inspection must be performed.

#### INSTALLATION

The panel moves slightly based on climatic and temperature variations. To ensure that this can be accommodated, mount the screw in the centre of the pre-drilled holes. Perform some on-site tests to calibrate the torque of screw gun prior to installation.

Max torque = 2/3 of the average test torque.

The screw should fasten the panel. The correct torque is determined based on the effect on the panel and the desired end result.

STENI AS reserves the right to change product composition and specifications without prior notice. STENI AS accepts no liability for printing errors.